

OLC812 is a protocol converter used for example by Crestron to communicate with the OKERO OLC bus. The interface is based on simple ASCII strings which are converted to OLC messages. The strings are sent using the RS232 protocol.

As an option OLC812 can be delivered with fully isolated in and outputs. OLC812 can function in both OLC Basic and Advanced systems and does also support DMX direct control via OKERO:s light control systems OMBmega and OMBmini.

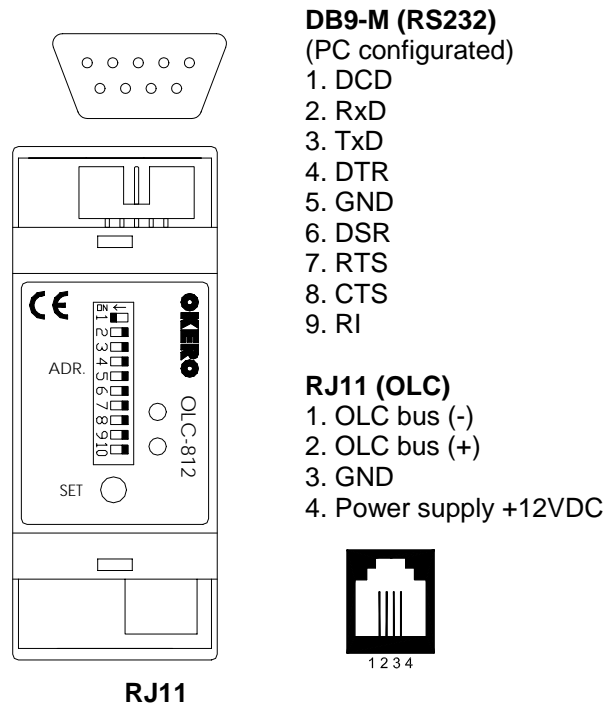
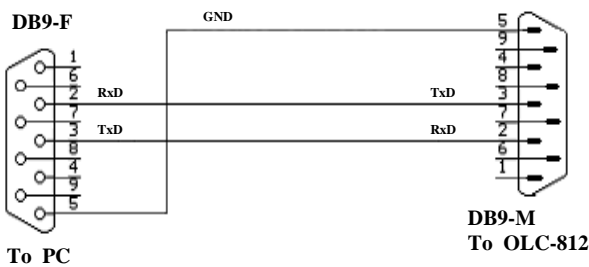

Figure 1. OLC812 frontview



**Function**

OLC812 converts ASCII strings to messages on the OLC bus via RS232. Further information about the ASCII string format is found later in this manual. OLC812 is supplied with power from the OLC bus and can be fitted in both OLC Basic and Advanced systems.

**Configuration**

User can only configure parameters regarding the

RS232 communication. The OLC bus communication need no configuration since there are different RS232 command set for different applications. See the table below for a description of the address switches.

Dip-switch	Function
1	Baudrate #1
2	Baudrate #2
3	Echo enable <i>Used with a terminal to watch typed characters.</i>
4	Handshake enable
5	OFF, No function
6	OFF, No function
7	OFF, No function
8	OFF, No function
9	OFF, No function
10	OFF, No function

Function switch table OLC812

**Baudrate**

The baudrate is set using the two first switches. Four different baudrates are possible and are displayed in the table below. The highest possible baudrate should be selected since the OLC bus is using 9600bps.

Switch 1	Switch 2	Baudrate
OFF	OFF	1200bps
ON	OFF	2400bps
OFF	ON	9600bps
ON	ON	19200bps

Baudrate table OLC812

**RS232 Protocol**

**OLC Basic**

'Basic' commands can be sent using both main and sub address or just the main address. If the sub address is left out the command will control all units with the same mainaddress regardless of their sub address. Notice that some commands requires the sub address, see examples below. If the main address is 00 all units on the OLC bus is controlled regardless of their address settings.

Command string syntax:

#aak\* or #aaCuuk\*

- # = start character (ASCII-kod 35)
- aa = main address 01-63 eller zero address 00
- k = command (1-10 characters), see list below
- uu = sub address 00-15, specifies a unit within a main address
- \* = end character (ASCII-kod 42)

Command (k)	Description	Example
@ddd	Set absolute value. ddd is the value 0-255 (0-100%).	#01C00@255* Sets memory 01:00 to full (100%)
+ddd	Increase value by ddd. ddd is the value 0-255 (0-100%). If a memory is 200 and then increased by 23 steps the new value will be 223.	#01C25+100* Increases memory 01:25 with 100 steps
-ddd	Decrease value by ddd. Same as for '+ddd' but with opposite result.	#01C04-010* Decreases memory 01:04 with 10 steps
mm	Activate (call) memory mm. 'mm' can be 01-99. Each dimmer in the OKERO OLC dimmer series has 99 memories that holds one individual level each. Normally these memories are called from button panels.	#0105* Activates memory 01:05
S	Store level in activated memory (fadetime is also saved). This command makes it possible to adjust and store memories and fadetimes of a dimmer on remote.	#01S* Store activated memory for address 01

*Command table OLC Basic*

**RS232 Protocol**

**OLC Advanced**

In an OLC Advanced system all functions are controlled by an OKERO OMBmega or OMBmini control system. These functions are called via events which are messages on the OLC bus. An event can be used for example to load light presets or to store changes in a light preset.

The event address must be assigned a function in the OKERO OMB system before it can be used.

Command string syntax:

#k\*

# = start character (ASCII-kod 35)

k = comman, see list below

\* = end character (ASCII-kod 42)

Command (k)	Description	Example
Ea	Send an event on the OLC bus. 'a' is the event address 0-65000 and can be 1-5 figures long. When events are raised by other devices on the OLC bus these can be read on RS232. Apart from sending event messages via RS232 five figures are always used to indicate the event address when reading data. (addr. 1 = 00001).	#E354* Sends event 354.
Ac@v	Set one OLC output to an absolute level. 'c' defines which address to control (1-65000). 'v' defines the new level (0-255) equal to 0-100% output. 'c' can be 1-5 figures and 'v' can be 1-3 figures long.	#A43@255* Set level for OLC output 43 to 100%.
Ac+v	Increase level for one OLC output. 'c' defines which address to control (1-65000). 'v' defines how many steps to increase (1-255). 'c' can be 1-5 figures and 'v' can be 1-3 figures long.	#A1245+10* Increase level for OLC output 1245 by 10 steps.
Ac-v	Decrease level for one OLC output. Same as for 'Ac+v' but with opposite result.	#A4-10* Decrease level for OLC output 4 by 10 steps.

*Command table OLC Advanced*

## RS232 Protocol

### OMB direct control

The following series of commands are used to control the OKERO control systems OMBmega and OMB-mini. In combination with an event for a 'store command' these commands can be used to change and store light presets from other type of control systems such as Crestron etc.

Command string syntax:

#Oak\*

# = start character (ASCII-kod 35)

O = defines OMB controlling

a = OMB address 0-255

k = command, see list below

\* = end character (ASCII-kod 42)

Command (k)	Description	Example
Tt	Sets the OMB general tuning time which is used as fadetime between two light presets. t can be 0-255 and defines the time in seconds. Value (t) can be 1-3 figures.	#O1T200* Set general tuning time for OMB with address '1' to 200 seconds.
Dc@v	Set one DMX channel to an absolute level. 'c' defines which channel to control (1-512). 'v' defines the new level (0-255) equal to 0-100% output. 'c' and 'v' can be 1-3 figures.	#O1D512@255* Set level for DMX channel 512 to 100% for OMB with address 1.
Dc+v	Increase level for one DMX channel. 'c' defines which channel to control (1-512). 'v' defines how many steps to increase (1-255). 'c' and 'v' can be 1-3 figures.	#O1D1+10* Increase level for DMX channel 1 by 10 steps in OMB with address 1.
Dc-v	Decrease level for one DMX channel. Same as for 'Dc+v' but with opposite result.	#O1D1-10* Decrease level for DMX channel 1 by 10 steps in OMB witch address 1.

*Command table OMB direct control*

## RS232 Protocol

### Examples

This example uses one OKERO OMBmega/OMBmini control system and remote preset load and preset level adjustments. RS232 protocol is OLC Advanced and OMB direct control commands. The command syntax details are shown in a previous section of this manual.

Assumed event addresses: (these addresses are predefined in the OMB system)

- Preset #1 load @ event 1
- Preset #2 load @ event 2
- Save command @ event 65

OMB has address 1

To load a light preset send an event with one of the predefined addresses:

#E1\*

To set DMX channel 10 to full level send the following string:

#O1D10@255\*

To increase DMX channel 2 by 10 steps send the following string:

#O1D2+10\*

To save the changes to previously loaded preset send the event that calls the Save command:

#E65\*

Notice that presets have to be loaded before levels are changed. If a new preset is loaded before saving changes will be lost.

**Technical spec:**

Powersupply	+12-15VDC 100mA @ 12VDC
OLC protocol	OLC Advanced/OLC Basic
RS232 port	Full duplex, RTS/CTS support
Ambient temperature	Max 40 degrees C.
Connection	Screw terminals/ RJ11,DB9 connector
Enclosure	2 module standard case
Size	90x35x59mm

<b>Model</b>	<b>Article number</b>
OLC812 with screw terminals	<b>OLC812-PL</b>
OLC812 with RJ11/DB9 connectors	<b>OLC812-RJ</b>